

/ Checkweighers Food

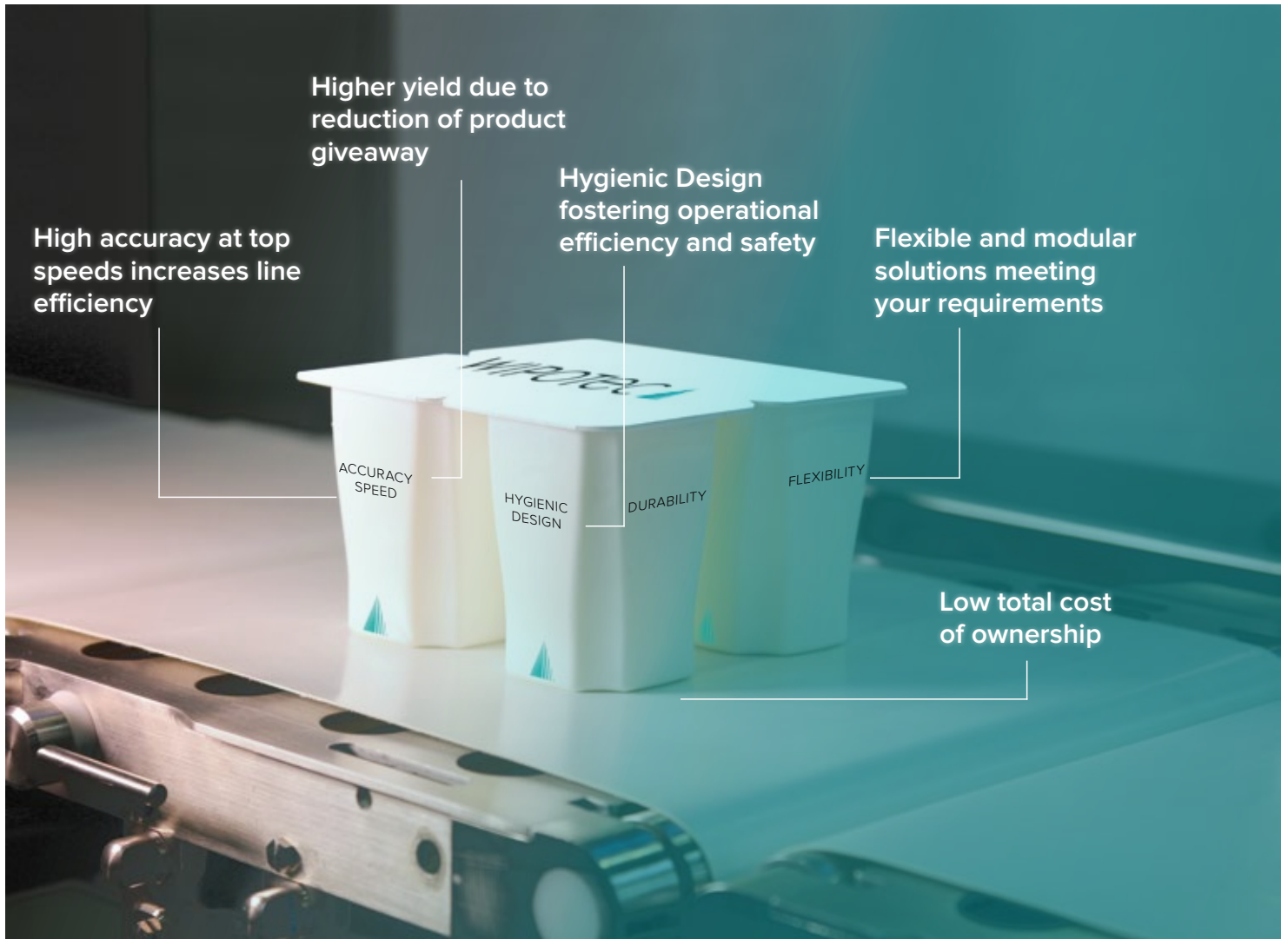

High-precision and ultra-fast **solutions** for maximum **efficiency** in **industrial food production**

/ Outstanding high-tech

for the highest precision at maximal throughput rates

Content

4 Food checkweighers

Unsurpassed speed and precision in a modular hygienic design

5 Wipotec

All expertise under one roof: globally respected, independent, flexible and innovative

8 Comscale4

Quality Data Management

10 EDK – weigh cells from Wipotec

Fast and precise weighing results

16 HC-M series

High precision for mid-range speeds

18 HC-M-VA

Solid stainless steel checkweigher for wet areas

19 HC-M-WD

Robust wash-down design for maximum hygiene

20 HC-M-MDi

Weighing and metal detection in one integrated unit

21 HC-M options

Diverse options for your custom application

22 HC-A series

For the highest standards in dynamic weighing

24 HC-A components

Top quality modules for your success

Machine systems

12 EC-E series

Compact design, big performance

14 EC-E-VA

Compact technology in stainless steel design

15 EC-E options

Modular design for your individual requirements



HC-M-MDi

25 HC-A-VA

The all-rounder in solid stainless steel for wet areas

26 HC-A options

Maximal flexibility for tailor made solutions

28 HC-A-Multi

High performance checkweighers for multi-track operations

29 HC-A-MI

Precision weighing for the lightest objects

30 HC-A-MDi

Weighing plus metal detection for maximum product safety

31 Heavy load checkweighers

Precision weight determination for heavy loads

X-ray and optical inspection

32 X-ray inspection systems

Brand protection through food inspection and safety checks

33 SC-W

Space-saving combination of checkweigher and X-ray inspection

34 SC-V

X-ray inspection and optical checks integrated in one structural design

Service

35 Reliable expert service

Our comprehensive knowledge is available to you anywhere in the world



SC-V

/ **Modular checkweighers** tailored to the requirements of your food processing operations

Checkweighers are highly precise measuring instruments that have become an integral part of today's industrial manufacturing processes. Almost every branch proceeds from the premise that combining high precision with the maximum possible throughput rates will maximise profit. Whereas underfilled products may lead to costly recalls and irreparable damage to your reputation, overfilling of products will have a negative effect on your productivity data. The highly precise weight measurement of your products is clearly a decisive factor in terms of the quality of your production. Moreover, it is a criterion that affects your long-term market position.

Maximum flexibility for your application

Decades of experience as a supplier of dynamic weighing and inspection systems has provided Wipotec the knowledge of what criteria are needed to produce a top quality product range. For that reason, Wipotec checkweighers have the flexibility and the variety of product configurations to enable a perfect customization for your individual application needs.

The checkweighers from Wipotec possess outstanding technology combined in a hygienic design (from the standard model to the fully hygienic variant), which consistently measures up to the stringent requirements of the food industry. Beyond pure weight value determination, these checkweighers optimize your production processes with robust, high-tech machines that are simple to operate and quick and easy to clean. Outstanding precision is achieved through the use of EMFR Weigh Cell technology from Wipotec.

Easy to combine and integrate

To maximize product safety, Wipotec checkweighers can be combined in a compact design with additional inspection devices such as metal detectors or X-ray scanners. The compact weighing and inspection systems from Wipotec are easily integrated in existing production lines. They are characterised by their safety, durability, and dependability – for you, the practical and perfect technology investment for a prosperous future.

Options & Throughput



E Essential

EC-E for simple applications, optimal price-performance ratio



M Medium

HC-M high performance in midrange application areas



A Avantgarde

HC-A innovative pioneer for the broadest spectrum of applications



Wipotec Headquarters

/ **Combined expertise under one roof**

Cutting-edge technology

Made in Germany

Wipotec is a sales and service company for dynamic, high-precision weighing and inspection solutions. As a wholly-owned subsidiary of the high-tech specialist Wipotec, which develops and produces all machinery solutions at its headquarters in Kaiserslautern, Wipotec has been setting global standards in the production lines of leading manufacturers for more than 30 years. Throughout the world, customers in the pharmaceutical, food and chemical industries and in

the mail and logistics sectors highly appreciate the solutions provided by Wipotec.

Excellent solutions for your application

Wipotec stands for sophisticated high-tech systems with maximum ease of use. The impressive product portfolio provides solutions for nearly all customer applications. If necessary, we take special requirements and conditions into account in supplying customized equipment



Extraordinary manufacturing depth, all side by side

Wipotec contributes great importance to the in-house development of all necessary technologies as well as the in-house manufacturing of all core components. Consequently, we develop a depth of manufacturing that differentiates us from other vendors and makes us largely independent of suppliers, while forming the basis for our delivery reliability. At Wipotec, the entire value chain from basic research, to planning, design, and manufacture to sales and service is all under one roof. The benefit of short channels of communication is the guarantee of maximum flexibility in the implementation of every individual product configuration. No matter how unusual your application may be, we will show you a possible solution that is sure to convince you.

That's what makes the difference



*Ein Unternehmen
muss zum
Wohlergehen*

Zitat ist noch deutsch

*nicht nur kurzfristig,
sondern
nachhaltig.*

Theo Düppre
Gründer und CEO von Wipotec



/ Globally respected, independent, flexible, and innovative: That is Wipotec

Wipotec weighing technology is used worldwide

About 20,000 checkweighers from Wipotec have been successfully deployed worldwide. This figure is a confirmation of the outstanding expertise from the company. An unbeatable product range and exceptional service are reason enough for a number of well-known firms in all industries around the world to choose our reliable weighing and inspection systems.

- Globally respected partner in industry
For more than 30 years
- Worldwide presence thanks to numerous
Subsidiaries and partners
- Founder managed company
- Company with high innovation power through large
r&d effort, incl. Basic research
- All expertise combined under one roof
- In-house production of all key components
- Broad product range for almost every Application
- Broad experience in implementing
Customer-specific systems
- Use of high precision wipotec weighing
Systems for optimum product quality
- Member of the european hygienic
Engineering & design group (ehedg)
- Outstanding service capabilities

Come and visit us!

Interested in the high-tech solutions from Wipotec? Perhaps you would like to visit our ultra-modern plant. Our prominent market position is no accident, but rather the logical consequence of the creative and competent efforts made by our staff on behalf of our customers. Come and see for yourself.

Just schedule an appointment for a tour with us:

✉ trackandtrace@wipotec.com

/ **Comscale4:** Web-based network enabled software for the capture and analysis of relevant production data

A main factor in increasing production efficiency is a regular and exact analysis of all available production data. This is especially true in large factories and multi-site operations that are dependent on a flexible, web-based quality data management system like Comscale4, a system offered by Wipotec.

The user-friendly Comscale4 software components, customized for your needs, connect any number of checkweighers and other inspection machines (X-ray scanner, metal detectors) to separate selectable sites. At any time, you can retrieve all available data, generate statistics, take important actions, and share data with partners throughout the enterprise. Comscale4 provides the ideal overview of your entire production in real time. Your quality assurance starts here!



Comscale4 Basic functions

Safety	Loss-free data transfer in real time
Transparency	Full data view from any site for all integrated machines and lines
Control	Operate/parameter changes via PC and mobile phones
Review	Data analysis, storage, and graphical evaluation for further higher-level use
Flexibility	Integration of various inspection devices (checkweighers, metal detectors, X-ray scanners, etc.)

Comscale4

Quality data management for the entire company

- Production** Central production records and data collection, prepackage regulations documentation and online monitoring all linked to the production lines
- QS** Targeted analysis of QA features, random attribute and calibration check
- Administration** Tracking metrics and documentation of operating performance
- Management** Decisions of the highest priority



Comscale4 Main menu

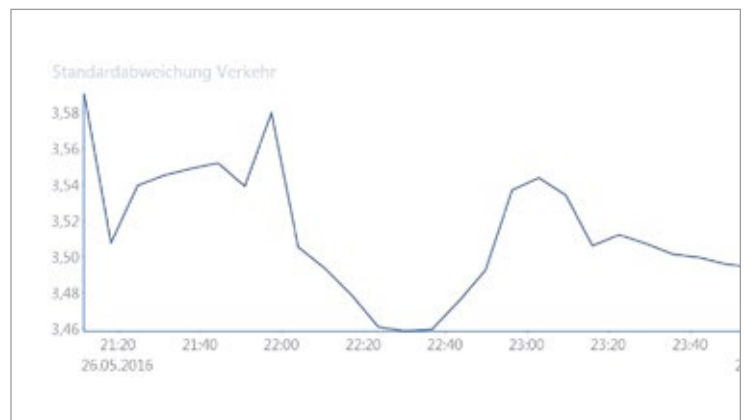
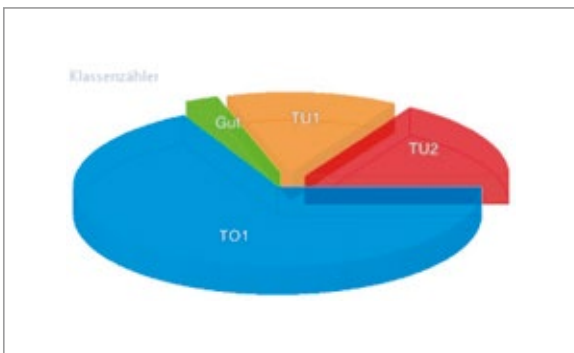

Comscale4: Powerful web-based software for perfect quality and production control

/ **EMFR** – Electro-magnetic force restoration

The decisive advantage of the Wipotec EMFR Weigh Cells is provided by their very short settling time. They are extremely fast and supply highly accurate weight values in comparison to other measuring methods that rely on strain gauges. Furthermore, they provide space and cost savings when integrated in existing systems.

EMFR – the principle of Electro-Magnetic Force Restoration

Wipotec weighing systems operate on the principle of electro-magnetic force restoration (EMFR). The weighing method can be compared in principle to a simple beam balance. The objective is to determine the force applied at one end of a lever arm. In this case, the weight forces the coil installed on the other side of the balance out of a magnetic field. An optical positioning system senses

the smallest displacement and reports this to a high precision control system that readjusts the compensation current and restores equilibrium to the balance. The compensation current is measured through a precision resistor and further processed by a micro-processor system for immediate output as a digital weight value. Checkweighers from Wipotec with EMFR weigh cells provide the winning edge. Depending on the series, the measurement range goes from 1 microgram to 120 kilograms.

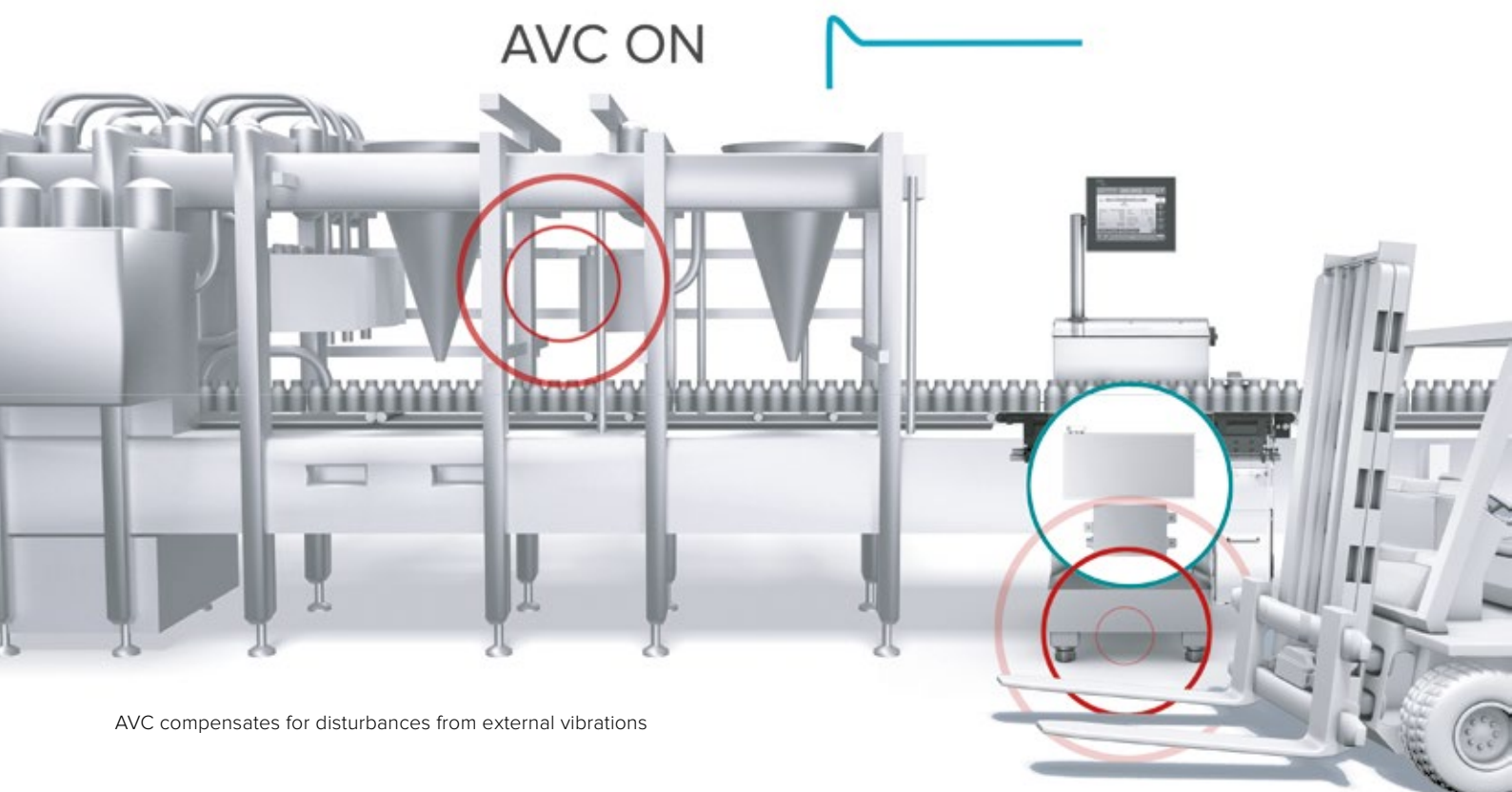

AVC compensates for disturbances from external vibrations

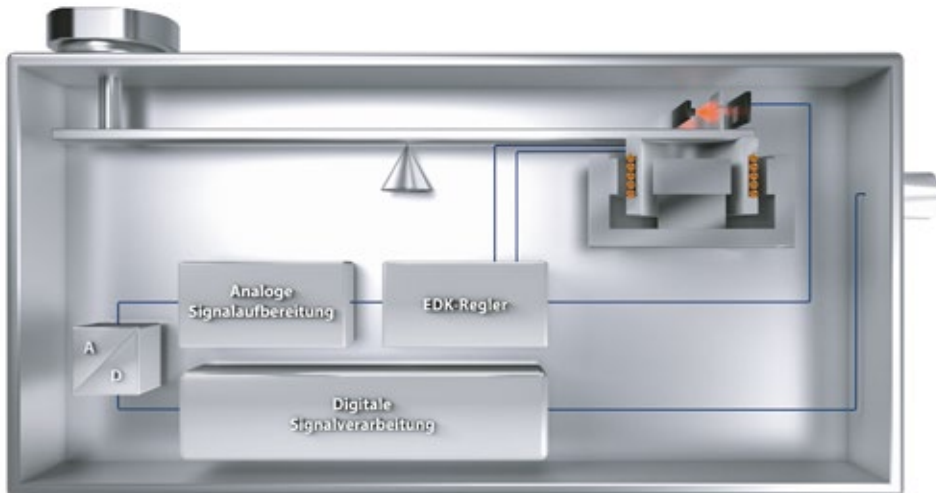

EMFR weigh cells enable lightning-fast weighing results

AVC (Active Vibration Compensation): Greatest accuracy in challenging environments

EMFR Weigh Cells from Wipotec can be equipped with AVC technology, as required. AVC (Active Vibration Compensation) technology filters out all operational interference that could affect the measuring results, thereby enabling the use of the weighing system in locations that are not free from external sources of vibrations (for example, forklift traffic).

Conformity marking of automatic checkweighers in compliance with MID

Wipotec is certified according to ISO 9001 and authorized to carry out a conformity evaluation according to module D of the "Measuring Instruments Directive" (MID, 2014/32/EU). The Directive bindingly regulates and harmonizes for all EU Member States, EFTA as well as Turkey the key requirements relating to measuring devices and their commissioning. ▲

Our customers benefit from MID in several ways:

- Installation, commissioning, and conformity assessment (formerly, initial verification) from one supplier
- Trade barriers eliminated within the EU
- A homogeneous level of protection by means of harmonized technical requirements

/ Compact design, big performance

Capable of 150 weight values per minute, the EC-E is the right choice for you. The intuitive user interface ensures convenient operation via a clearly structured, 8-inch colour touchscreen. The EC-E checkweigher precisely weighs each individual product, records individual values, and ejects incorrect weight packages via the fully automated sorter. Your data is correctly and completely collected and you have the certainty that only factory compliant products leave your production halls.

The checkweighers ease of use virtually excludes all incorrect entries. A reliable high-tech machine, especially in the dry foods sector, with a very good price-performance ratio in the EMFR entry segment.



Main Features

- Wipotec EMFR Weigh Cells
- Stainless steel frame
- Stainless steel cabinet with integrated control system
- Three NT30 conveyors (infeed, weighing and outfeed); Lightweight construction
- Maintenance-free servo drives
- One sorter attachment (air blast)
- User friendly interface via 8" colour TFT touchscreen display
- Memory for 50 different product parameters (option to expand to 200)
- Line synchronization with potential-free switching contacts/binary signals
- Extensive statistical functions/histograms

Your Benefits

- High throughput rate of up to 150 pcs/min
- Precise and reliable weighing results to increase plant efficiency
- Very good price-performance ratio
- Demand-oriented product options

Technical Data	
Working height ¹⁾	650–800 ²⁾ / 750–900 / 850–1,000 / 950–1,100 ²⁾ mm
Conveyor width	150 / 200 / 300 ²⁾ mm
Weighing conveyor length	200 / 300 / 400 / 500 ²⁾ mm
Infeed conveyor length	300 / 400 / 500 / 600 mm
Outfeed conveyor length	300 / 400 / 500 / 600 mm
GWR (Gross weight range)	1,500–6,000 g
e (min. calibration value)	≥ 0.5–≥ 2.0 g
d (Displayed value)	From ≥ 0.2 g
Standard deviation ³⁾ (1s)	From 150 mg
Max. output ³⁾	150 pcs/min
Rated voltage	L1/N/PE; 100–240 VAC
Rated frequency	50/60 Hz
Connect load (power capacity)	Approx. 0.8 kVA
Compressed air supply (option)	8 bar approx. 10 NI/min quality class (according to ISO 8573-1) [5:3:3]
Machine weight (standard application)	100 kg
EU-type examination certificate	DE-18-MI006-PTB001 (MID)

¹⁾ Working height must be specified when ordering

²⁾ Optionally, surcharge

³⁾ Depending on product shape, product behavior, transport speed and environmental condition

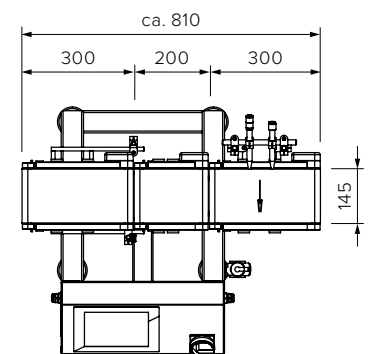
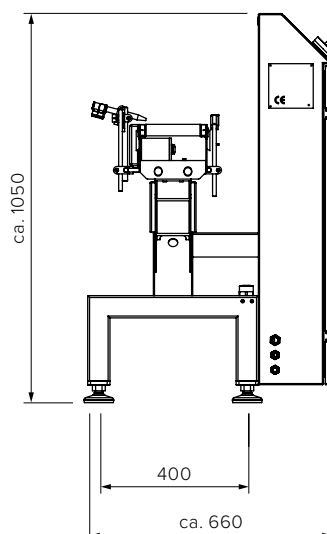
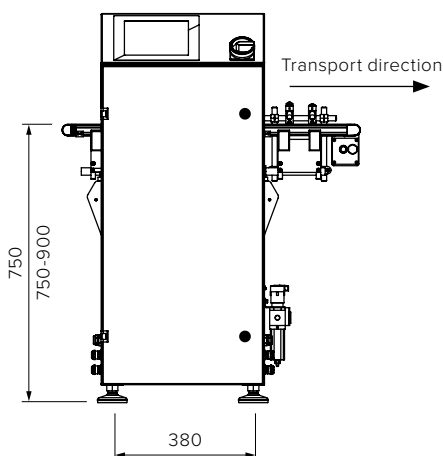

These specifications are reference values of the standard machine excluding application- or weighing-specific add-on parts. All entries in mm | Drawing shows sample version.



EC-E-SL for large and heavy product formats



The EC-E product series for reliable weighing

/ Compact technology in stainless steel design for use in wet environments

The EC-E-VA model has an innovative design with weigh cells, drives, and belt construction in stainless steel (protection class IP65) and is recommended for use in light to average humidity environments.

The Wipotec Weigh Cell used operates on the principle of Electro-Magnetic Force Restoration (EMFR) and stands for the fastest high precision measurement results. The EC-E-VA is fast and easy to integrate in any production line. This machine is your reliable instrument for optimal efficiency with up to 150 weight values per minute.

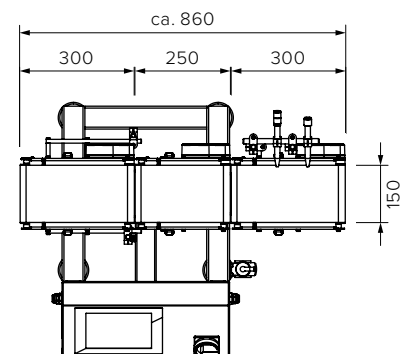
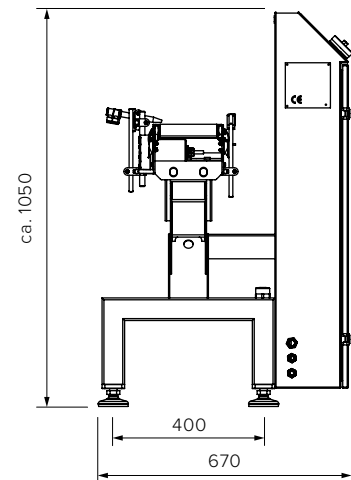
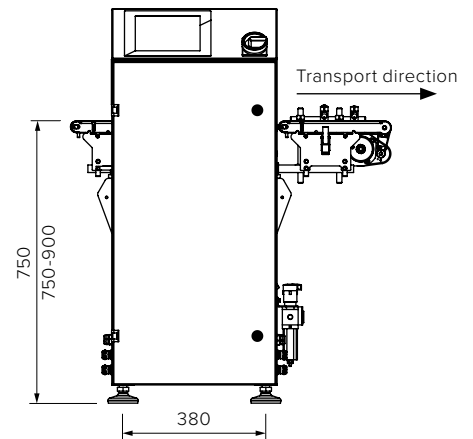
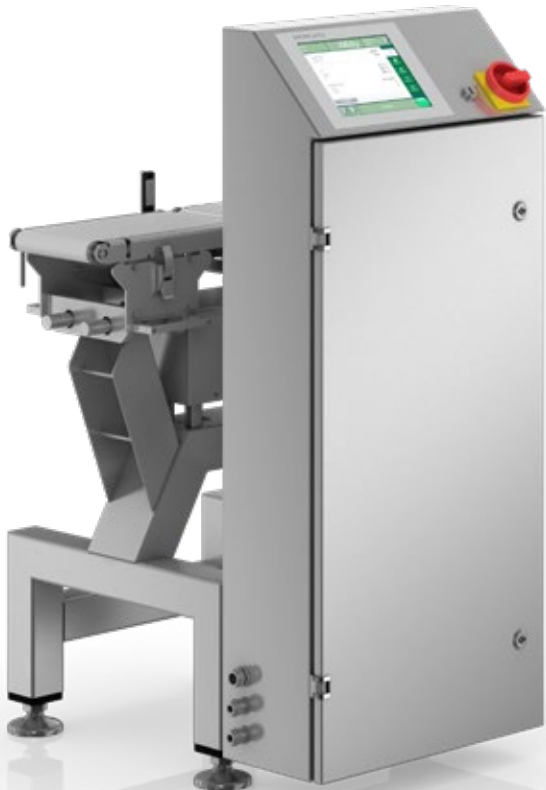

/ **EC-E options:**

Modular design for your individual needs

Mechanics

- Various belt lengths and widths
- Additional NT30 conveyor belt
- Metal detector belt NT30
- Special working heights
- Supporting feet

Product handling

- Lateral guide rails
- Rolling knife edge
- Bridge plate between belts

Statistics/Data export

- USB Stick
- Single value transfer
- Comscale4
- Paper roll printer
- Standard interfaces
- Connection to Freeweigh.Net

Monitoring functions

- Product flow control
- Pressure switch
- Fill level check/collector box
- Emergency stop (various versions)
- Metal detector connection

Weighing technology

- Fully covered weighing belt as protection against draughts
- Approved variant available
- Performance of MID conformity assessment (formerly, initial verification)

Electrical options

- Lamp tower (one or three step)
- Signal horn
- Supplemental potential-free I/O

Sorting options

- Pusher
- Free standing hinged flap
- Flipper
- Second sorter
- Rejection bin, lockable
- Stainless steel drop shaft

Control functions

- Mean value regulation (for filler head)
- Expandable item storage

/ High precision for the average speed range

The dynamic checkweighers of the HC-M series provide the perfect weighing technology for challenging medium range checkweighing applications. They are the link to the series EC-E and HC-A scales and provide up to 250 weight values per minute for the complete medium range.

The HC-M is the most convenient answer, whether you need to check the current actual weight or perform a completeness check, or a sort, or a classification. The base frame is made of solid stainless steel and enables high precision weight determination at average to high conveyor speeds or throughput rates and provides 100% product checks in accordance with national pre-package regulations.

The lightweight, patented conveyor system and carefully tuned drive concept ensure smooth, fast and safe transport. Component design facilitates implementation of custom solutions for various product shapes and forms. A sophisticated and wide range of sorters (pusher, air blast, etc.) are available for the reliable ejection of products having an incorrect weight, without interfering with the production.

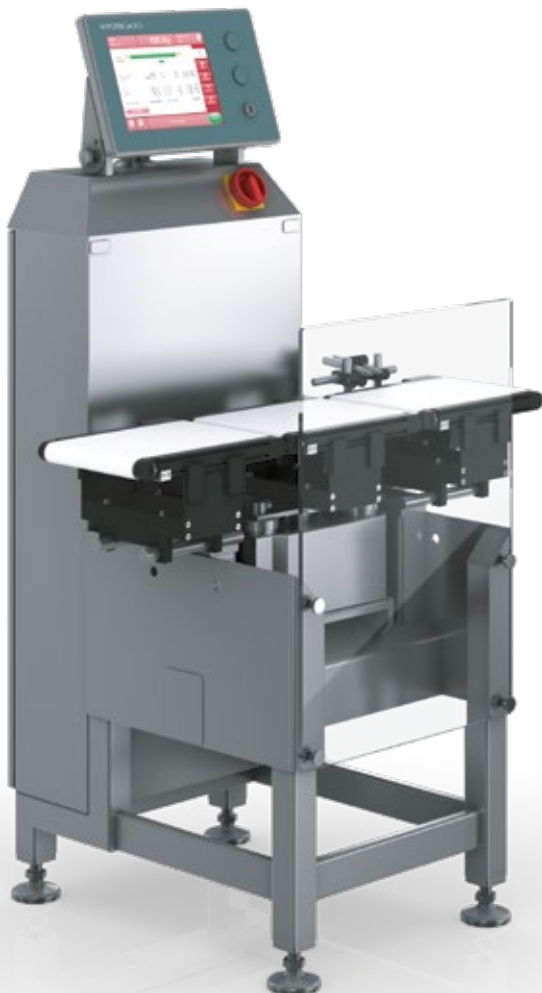

Main Features

- Entire machine in stainless steel housing with in-feed, weighing, and outfeed conveyors (NT30)
- One sorter (air blast or pusher)
- Maintenance-free servo-drives
- Certified (MID)
- Wipotec EMFR Weigh Cell
- Simple, menu-directed operation via a 15" colour TFT touchscreen
- Memory for 100 product parameters
- Easy, tool-free exchange of belts and conveyors
- Flexible integration in production lines
- Line synchronization with potential-free I/O signals
- Extensive statistical functions/histograms for production documentation

Your Benefits

- Maximum throughput 250 pcs/min
- Exact fill results for higher productivity
- Efficiency improvement through simple and user-friendly controls
- Requirements-based modularity for the greatest flexibility

Technical Data	
Working height ¹⁾	700–850 / 800–950 / 900–1,050 mm
Conveyor width	120 / 150 / 200 / 300 ²⁾ / 400 ²⁾ mm
Weighing conveyor length	200 / 250 ²⁾ / 300 / 400 / 500 ²⁾ mm
Infeed conveyor length	200 / 300 / 400 / 500 / 600 mm
Outfeed conveyor length	200 / 300 / 400 / 500 / 600 mm
GWR (Gross weight range)	750–7,500 g
e (min. calibration value)	≥ 0.01g–≥ 1.0g
d (Displayed value)	From ≥ 0.01g
Standard deviation ³⁾ (1s)	From 100 mg
Max. output ³⁾	250 pcs/min
Rated voltage	L1/N/PE; 100-240 VAC
Rated frequency	50/60 Hz
Connect load (power capacity)	Approx. 0.8 kVA
Compressed air supply (option)	6 bar approx. 16 NI/min quality class (according to ISO 8573-1) [5:3:3]
Machine weight (standard application)	230 kg
EU-type examination certificate	DE-18-MI006-PTB001 (MID)



Simple operation: Colour TFT display with touchscreen



Air blast nozzle (on the right) for secure ejection of under or overweight products

¹⁾ Working height must be specified when ordering.

²⁾ Optionally, surcharge

³⁾ Depending on product shape, product behavior, transport speed and environmental condition

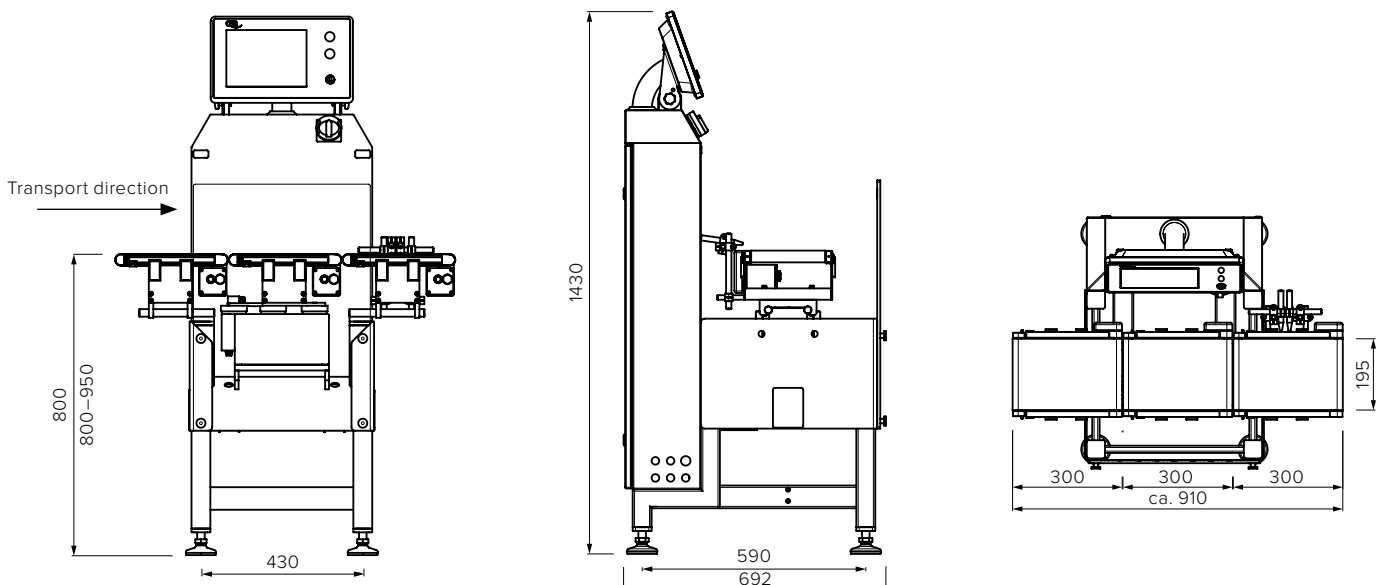

These specifications are reference values of the standard machine excluding application- or weighing-specific add-on parts. All entries in mm | Drawing shows design example.

/ The checkweigher in a solid stainless steel version for wet environments

The solid stainless steel construction of the HC-M-VA is the perfect answer. Other materials have been deliberately avoided in the product areas. This makes the HC-M-VA ideal for use in light to average humidity environments (protection class IP65).

The Weigh Cell with secondary hood, drive motors, and conveyors are all manufactured as stainless steel machine components. Additional options in stainless steel complete this outstanding package.

The stainless steel version of the HC-M-VA is a prime example of machine design as well as for product and consumer safety. Designed and implemented for frequent cleaning cycles, this machine very easily integrated in existing production lines.

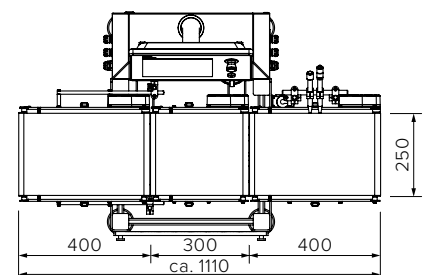
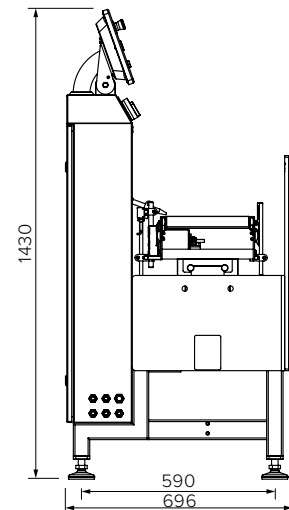
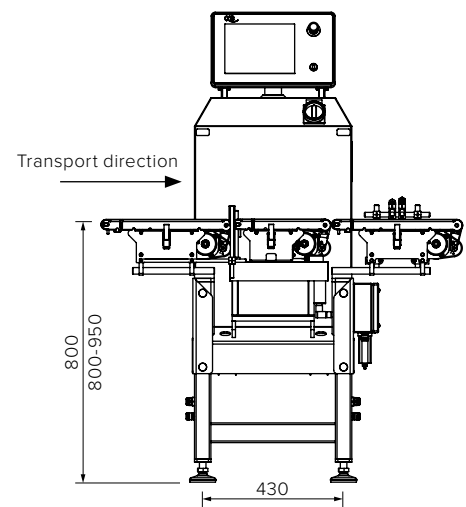

All entries in mm | Drawing shows sample version

/ Wash-down design for universal use and maximal hygiene

The HC-M-WD from Wipotec provides a reliable and robust checkweigher in an innovative, hygienic wash-down design. This model meets all statutory provisions for the food processing industry like IFS-compliant product control, and HACCP or LMHV/FDA (Food Hygiene Regulations).

Wipotec developed these dynamic checkweighers, which deliver outstanding values in terms of precision and throughput, to be maintenance-free, with stainless servo motors for use in operations with intensive and frequent cleanings. The well-designed performance features of the HC-M-WD model satisfy all cleaning criteria and the most stringent hygienic requirements of the food industry.

Rounded surfaces and defined drip edges in combination with an open design and protection class IP69K provide the best conditions for optimal hygiene. Ease of cleaning is ensured by the tool-free removal of the belts (excenter). An optional cleaning program package enables risk-free cleaning while in operation.

The machine underframe is also hygienically designed. The stainless steel design of the precision weigh cell with sloping housing and separate base for a vibration-free integration in the machine frame ensures reliable and highly precise results.

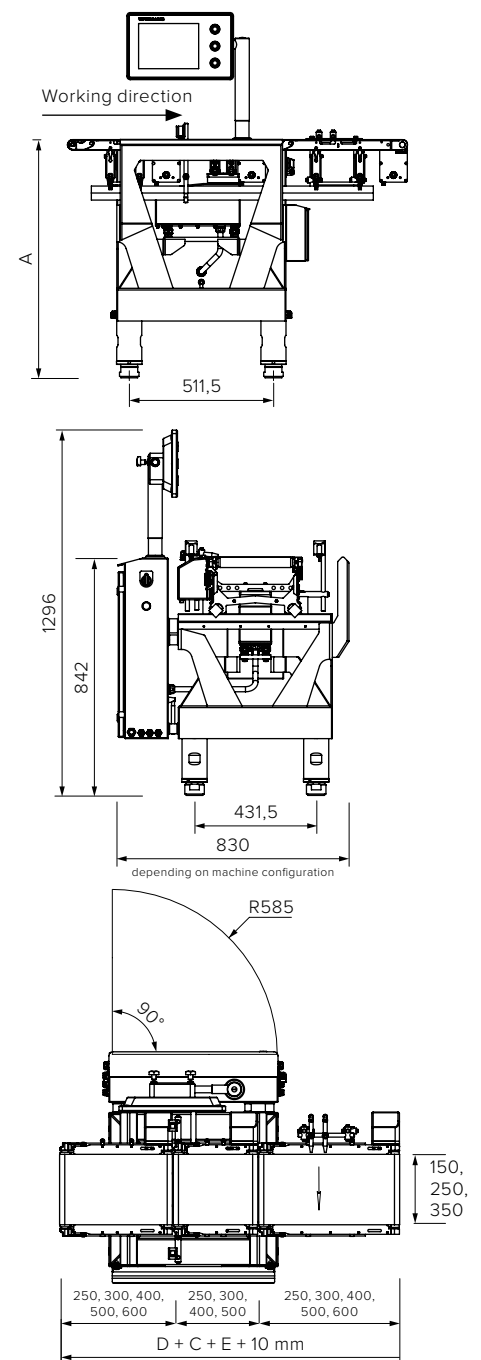

All entries in mm | Drawing shows sample version

/ Weighing and metal detection in one integrated unit

If high precision weighing of your products is not enough and you require an additional reliable inspection for metallic impurities, you need the HC-M-MDi. This machine is a high-tech combination scale and metal detector, together in one compact unit that sets the quality standard in terms of product safety.

The entire system is controlled via the menu-driven, user-friendly controls of the checkweigher. The central control point conveniently manages the product parameters, protocols, and production statistics. Naturally, you will find all of the conventional performance characteristics of metal detectors (for example, product tracking, compensating for the product effect, FPV compliance checks, etc.), provided in the HC-M-MDi. This model is a high-precision weighing instrument and fully integrated metal detector all in one compact unit.

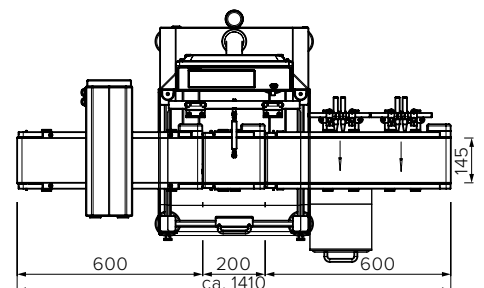
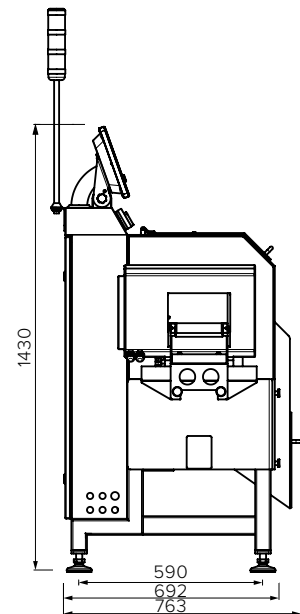
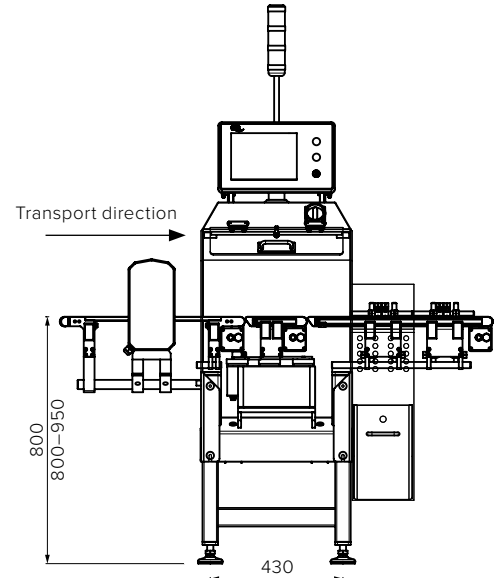

All entries in mm | Drawing shows sample version

/ **HC-M:** Diverse options for your custom application

Mechanical options

- Various belt lengths and widths
- Requirements-based transport system
- Free standing conveyor belt
- Combination frame (for metal detector)
- Metal detector belt
- Special working heights
- Supporting feet

Product handling

- Lateral guide rails
- Rolling knife edge
- Bridge plate between belts
- Fully adjustable settings for top belts, scooped belts, and lateral pressure belts
- Intralox linked chain belts

Statistics/Data export

- USB Stick
- Configurable statistics transfer
- Comscale4
- Paper roll printer
- XML and OPC interface
- Standard interfaces (profibus, Ethernet/IP)
- Connection to Freeweigh.Net
- Backup/Restore program package

Monitoring functions

- Product flow control
- Serial fault detection
- Sensor control
- Additional product controls (flaps, inclined angles)
- Pressure switch
- Fill level check/collector box
- Emergency stop (various versions)
- Potential-free infeed

Weighing technology

- Fully covered weighing belt as protection against draughts
- Approved variant available
- Performance of MID conformity assessment (formerly initial verification)
- Weigh cell with preload adjusted noise compensation
- Multi-interval/multi-range scale

Electronic options

- Lamp tower (one or three step)
- Signal horn
- Expandable product parameter memory
- Control over max. 5 transport drive motors
- Interfaced frequency converter
- Numerical remote display
- Supplemental potential-free I/O
- Integrated metal detector

Sorting options

- Pusher
- Free standing hinged flap
- Flipper
- Second sorter
- Rejection bin, lockable
- Stainless steel drop shaft

Control functions

- Mean value regulation (for single filler head)
- Mean value regulation (for dual filler heads)
- Floating mean value control
- Minimised ejections

/ HC-A series

For the highest standards in dynamic weighing

In terms of precision and throughput, checkweighers of the HC-A series are the logical response to meet the demands of modern, dynamic weighing technology. The machines provide the controls and engineering to create the ideal platform for implementing the complex regulation and control tasks. The HC-A is the basis for high end application-oriented systems that provide a maximum of 600 values per minute with 100% product monitoring.

This model significantly extends the application possibilities of the product line from Wipotec and completes our versatile product range, especially for high-end applications. This machine continues the use of our successful product and operating concept. In particular, the advanced solid stainless steel frame ensures extremely accurate weighing results at very high transport speeds or throughput rates.

The modular design facilitates the implementation of custom solutions for a variety of product geometries and forms. The sophisticated and wide selection of sorters (pusher, air blast, etc.) is designed to reliably eject products with incorrect weights with respect to packaging. The HC-A is characterised by its comprehensive product handling. For example, the top runner belts safely perform acceptance and acceleration of folded cartons just as the metering screw and lateral pressure belts safely separates and accelerates vials and bottles. The HC-A supports your efforts to minimise costly over-filling with a number of optional functions.

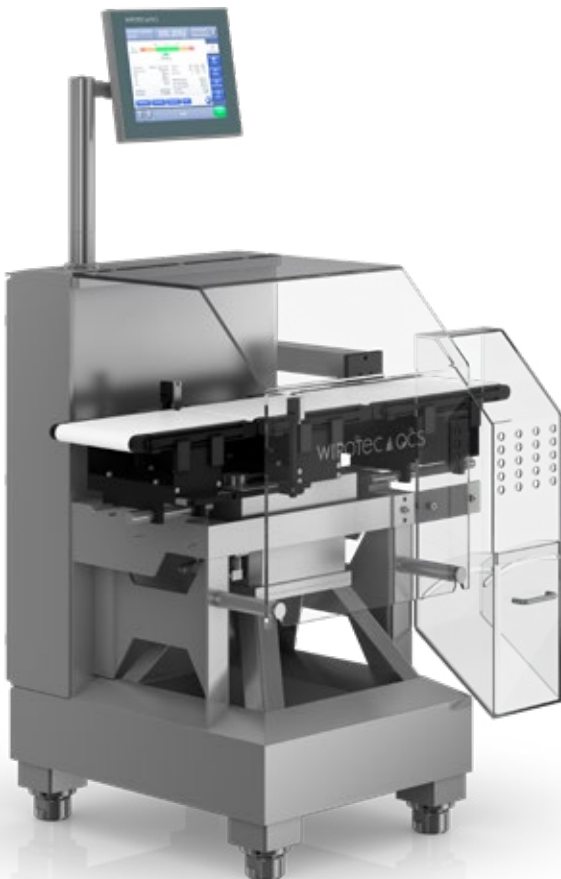

Main Features

- Sturdy, solid stainless steel frame
- One sorter (air blast or pusher)
- Maintenance-free servo-drive
- Certified (MID)
- Wipotec EMFR Weigh Cell
- Simple, menu-directed operation via a 15" colour TFT touchscreen
- Easy, tool-free exchange of belts and conveyors
- Flexible integration in production lines
- Line synchronization with potential-free I/O signals (expandable option)
- Variable conveyor widths and lengths
- Extensive statistical functions/histograms

Your Benefits

- Maximum output 600 pcs/min
- Exact fill results for highest productivity
- Efficiency improvement through simple and user-friendly controls
- Requirements-based modularity for the greatest flexibility
- Greater unit efficiency means a positive contribution to reducing TCO

Technische Daten	
Working height ¹⁾	700–850 / 800–950 / 900–1,050 mm
Conveyor width	120 / 150 / 200 / 300 / 400 ²⁾ mm
Weighing conveyor length	200 / 250 ²⁾ / 300 / 400 / 500 mm
Infeed conveyor length	200 / 300 / 400 / 500 / 600 mm
Outfeed conveyor length	200 / 300 / 400 / 500 / 600 mm
GWR (Gross weight range)	750–7,500 g
e (min. calibration value)	≥ 0.1 g ≥ 1.0 g
d (Displayed value)	From ≥ 0.01 g
Standard deviation ³⁾ (1s)	From 50 mg
Max. output ³⁾	600 pcs/min
Rated voltage	L1/N/PE; 100-240 VAC
Rated frequency	50/60 Hz
Connect load (power capacity)	Approx. 0.8 kVA
Compressed air supply (option)	6 bar approx. 16 NI/min quality class (according to ISO 8573-1) [5:3:3]
Machine weight (standard application)	250 kg
EU-type examination certificate	DE-18-MI006-PTB001 (MID)

¹⁾ Working height must be specified when ordering

²⁾ Optionally, surcharge

³⁾ Depending on product shape, product behavior, transport speed and environmental condition



Easy to comprehend and operate:
HC-A user interface



State-of-the-art HC-A weighing technology
as multi-track option

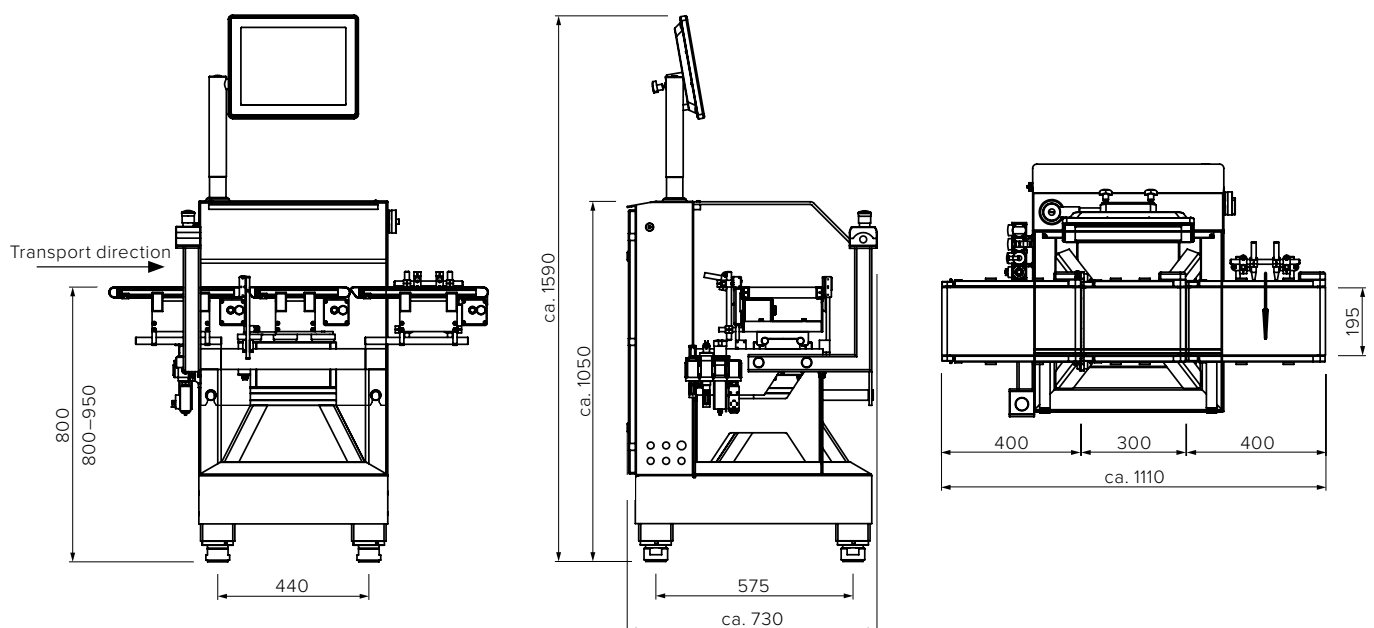

These specifications are reference values of the standard machine excluding application- or weighing-specific add-on parts.
All entries in mm | Drawing shows sample version.

/ HC-A modules: High quality components for your success

The sure and correct choice of checkweigher components is the basis for efficient dynamic weighing. Many years of experience in the design and manufacture of dynamic weighing systems lets you profit from the perfectly matched interplay of high precision weighing and high transport speeds.

GMP compliant design

The consistent implementation of GMP requirements (for example, sloped edges, hidden cable channels, easy to clean surfaces) ensures an easy integration of the HC-A in food production operations.

Sturdy frame

An especially robust underframe made of stainless steel ensures in conjunction with the integration weight, a secure foundation that safely dampens any spurious vibrations (for example, fork lift traffic).

Patented conveyor system

The lightweight, patented conveyor belts together with a carefully tuned drive concept, ensure the very smooth, safe, and reliable transport. In addition, the transport system is supplemented with a variety of handling systems (for example, metering screws).

Precision Weigh Cells

Designed especially for the requirements of dynamic high performance weighing, the weigh cells (1 ms sampling value) are optimally adjusted for each application. The highest accuracy, fastest speeds, and highest productivity are safely achieved.

15-inch colour TFT

The HC-A is equipped with a large high resolution colour TFT touchscreen. The display features a brilliant, high-contrast colour scheme.

Product flow control*

The optional product flow control monitors the product chain within the checkweigher and initiates an alarm if:

- Additional products wrongly enter the product flow
- Registered products are removed from the product flow
- A faulty product is mistakenly not ejected (cross verification in the accepted goods flow)

Remote operation*

The scales of the HC-A series can be remotely operated via an Ethernet-connection from a second control panel (option).

Sequential drive*

The HC-A checkweighers employ a motor management system that continuously governs the individual drive motors. If the transport speed of an upstream machine changes, the HC-A simultaneously maintains the metrological accuracy and automatically adjusts the sorting time (sequential drive optional).

Flap control*

The flap control option checks the proper closure of the packages. Improperly closed packages detected by the checkweigher are reliably ejected at the sorter. In the production statistics, improperly closed packages are recorded separately. The flap controls are sizing parts that can be easily set by a graduated dial for different package sizes.

Sensor control*

Another option is the continuous monitoring of all connected sensor by the checkweighers. The failure of a sensor - perhaps a loose cable - automatically triggers an alarm. A plain text alarm message stating the type sensor is displayed.

Floating mean value control*

The floating mean value control option enables the self-adjustment of the sorter dead zone for long wave variations of the package weights. The sorter's dead zone and the accepted goods zone are adjusted by means of the calculated floating mean value to a pre-defined tolerance range set by the user for the current production. The floating mean value control allows a narrow choice of selection limits while taking into account the variations in package weight within the production run.

/ Top quality components for your success

The HC-A-VA dynamic checkweighers in solid stainless steel provide the highest standards of precision and maximum throughput. This means the HC-M-VA (protection class IP65) is ideal for use in light to average humidity environments and easily integrated in existing production lines. As machine components, the weigh cells, motors, and conveyors are also constructed from stainless steel.

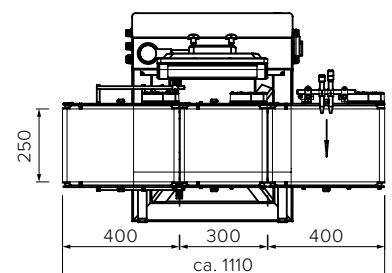
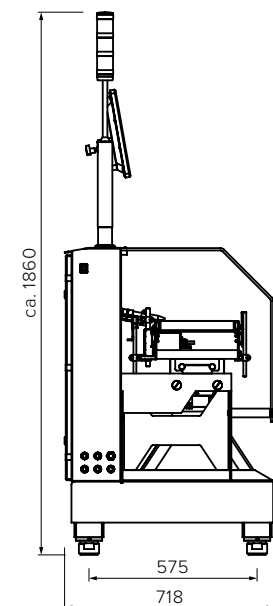
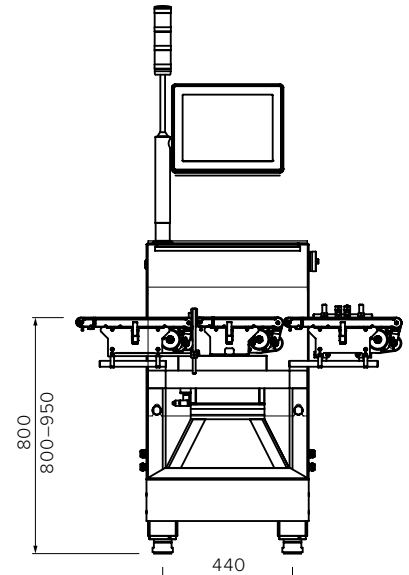

/ HC-A options: Modular components for your optimised application



The HMI of the HC-A offers simple and intuitive operation, convenience and ease of learning.



User-friendly homescreen



Clear graphics of mean value indication

Type	Date / time	exported
Intermediate statistics	2013-04-02 11:03:13	No
Cumulative statistics	2013-04-02 11:03:06	No
Cumulative statistics	2013-04-02 11:03:14	No
Cumulative statistics	2013-04-02 10:59:39	No
Cumulative statistics	2013-04-02 10:40:08	No
History of errors	2013-04-02 09:54:21	No
Intermediate statistics	2013-04-02 09:59:32	No
Article	2013-04-02 09:09:58	No
Signal checks	2013-04-02 09:09:21	No

Extensive statistical functions

/HC-A: vielfältige Optionsmodule

Mechanik 1

- Verschiedene Bandlängen und -breiten
- Mehrspuranlage mit Sammelbedienung
- Applikationsgerechte Transportsysteme
- Kombinationsgestelle (Metalldetektor, Lasercodierung, etc.)
- Metalldetektorband
- Sonderarbeitshöhen
- Stützfuß

Produkthandling 2

- Seitliche Führungsschienen
- Messerkanten (rollend)
- Übergangsbleche zwischen den Bändern
- Stufenlos einstellbare Oberläufer, Schnabelbänder und Seitenpressbänder
- Vereinzelungsschnecke
- Intralox Gliederkettenbänder

Statistik/Datenexport 3

- USB Stick
- Konfigurierbare Statistikübertragung
- Comscale4-Vernetzung
- Papierstreifendrucker
- XML- und OPC Schnittstelle
- Standard-Schnittstellen (Profibus und Ethernet)
- Anbindung an Freeweigh.Net
- Backup/Restore Programmpaket

Kontrollfunktionen 4

- Produktstromkontrolle
- Serienfehlererkennung
- Sensorkontrolle
- Zusätzl. Produktkontrollen (Laschen, Schräglage)
 - Druckwächter
 - Füllstandskontrolle
 - Auffangbox
 - Not-Aus, verschiedene Ausführungen
 - Nachkontrolle
 - Temperatursensoren

Fertig

Wägetechnik 5

- Vorlastangepasste Störgrößenkompensation
- Active Vibration Compensation (AVC)
- Tara-Brutto Wägesystem
- Milliliter-Programmpaket (ml-Anzeige)
- Wägebandvollabdeckung zum Schutz vor Zugluft
- Eichfähige Ausführung Kontrollwaage
- Durchführung MID-Konformitätsbewertung
- Mehrteilungs-/Mehrbereichswaagen
- Mehrspur-Wägesysteme
- Artikel Teach-In

Elektrik 6

- Lampenturm (ein- oder dreistufig)
- Signalhupe
- Erweiterung Produktparameter Speicher
- Steuerung von zusätzlichen Transportmotoren
- Motormischbetrieb (IMOT oder DC/AC-Antriebe)
- Ansteuerung eines Frequenzumrichters
- Numerische Fernanzeige
- Zusätzliche potentialfreie Ein- und Ausgänge
- Folgeantrieb
- Integrierter Metalldetektor

Sortierung 7

- Mehrfachsortierung
- Sortiereinrichtungen (Blasdüse, Pusher, Klappe, etc.)
- zusätzliche Sortiervorrichtungen
- Auffangbehälter, abschließbar
- Fallschacht aus Edelstahl
- Hochgeschwindigkeits-Ausleitsystem
- Servomotorische Ausleitsysteme

Steuer- und Regelungstechnik 8

- Mittelwertregelung (für bis zu 30 Füllköpfe)
- Remote Control zur Fernwartung
- Füllkopfbetrachtung mit Trendmeter und
- Individualstatistiken (für bis zu 30 Füllköpfe)
- Gleitende Mittelwertsteuerung
- Ausstoßminimierung

/ High performance checkweighers for multi-track operations

The HC-A multi-track systems are particularly well-suited for use with small package sizes (for example, stick packs or 4-sided sealed bags). Multi-track units are available in conventional conveyor belt systems and also as a push over variant. High-precision weight measurements with individual display are provided for each track (with the minimal mid-lane positioning). The rejection system can be track based or combined.

In the push over variant, the EMFR-Weigh Cell from Wipotec is completely decoupled mechanically from the product transport. Products are pushed by a "finger" (guided and driven from above) onto the weighing platform. The product transport is centrally managed by only one servo drive for the entire checkweigher (all tracks). The smallest feasible track separation and maximal accuracies are achieved using the push over method. Multi-track units are custom designed, developed, and manufactured to your specific requirements, dependent on the filling unit in operation and the product geometries.

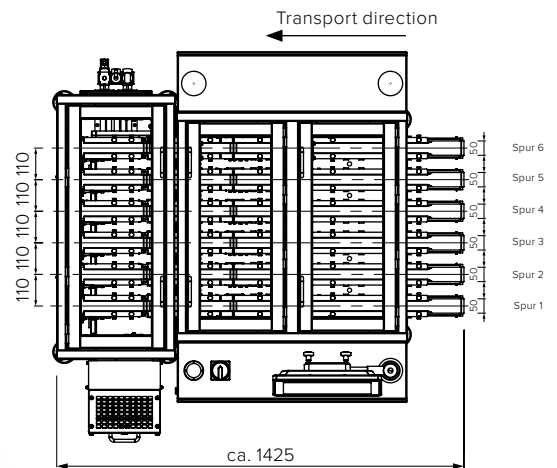
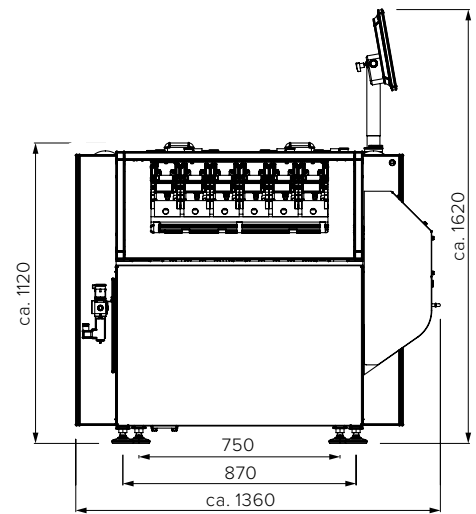
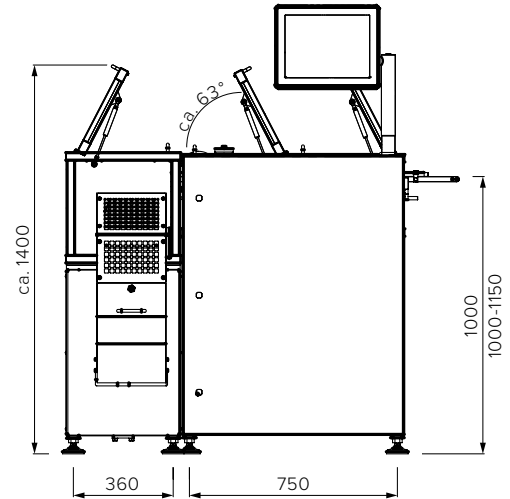

All entries in mm | Drawing shows sample version

/ Precision weighing for the lightest objects

The HC-A-MI is the perfect automated system for continuous and accurate weighing of ultra-lightweight parts (for example, stick packs) in the milligram range. Product infeed is product-specific and individually managed.

Vibrations in the production environment are suppressed through preload adjusted noise compensation (optional). Weight values are determined within fractions of a second. The classification of either accepted or rejected products, as well as the subsequent sorting, is done directly by the controls of the checkweigher. Because of its automated 100% monitoring, the HC-A-MI provides new possibilities in quality assurance for sensitive products and production processes. It is easily integrated into any production line.

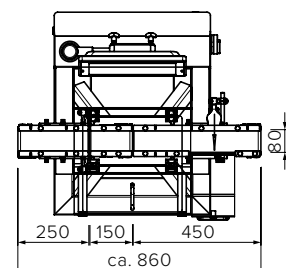
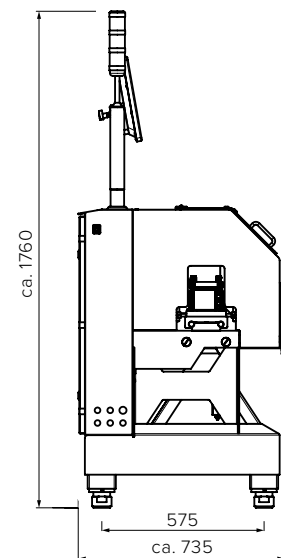
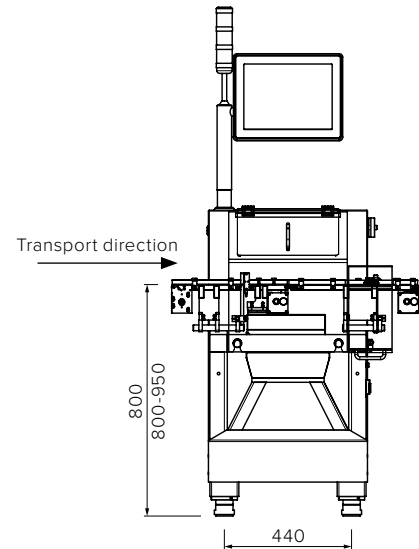

All entries in mm | Drawing shows sample version

/ Weighing plus metal detection for maximum product safety

The HC-A-MDi model is synonymous with high precision weighing in combination with extremely sensitive metal detection for optimal performance. It is a practical combination of inspection technologies in the interests of increased consumer safety and provides scales and metal detector in one space-saving unit, which can be operated from one HMI and easily integrated as part of any line.

Zitat weggelassen

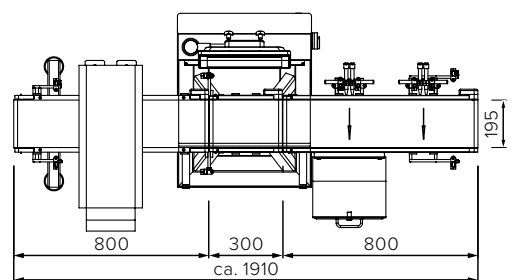
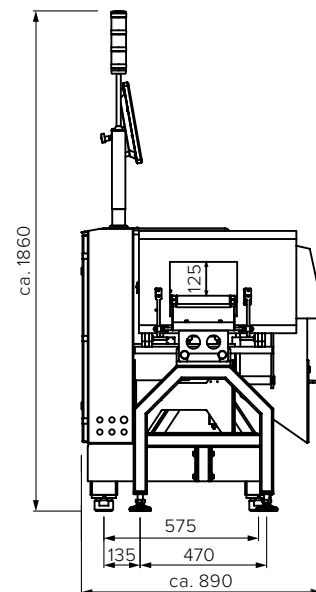
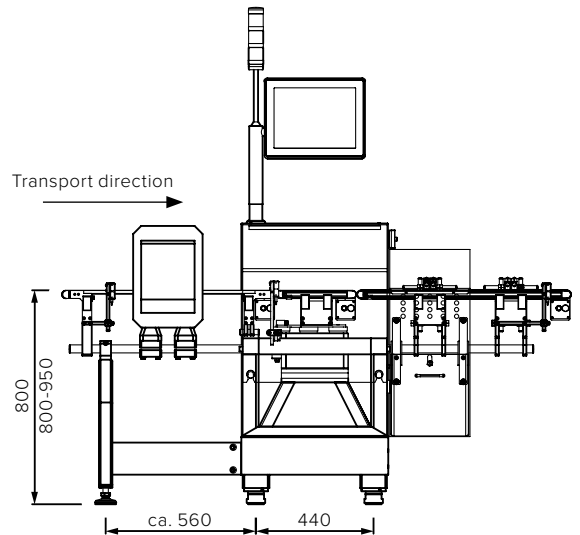

All entries in mm | Drawing shows sample version

/ Heavy load checkweighers

for precise weight determination

Do you need a reliable checkweigher for precise, dynamic weighing processes in the field of logistics and warehousing or in a wet-room with strict hygienic requirements? Your investment in a heavy duty model from the comprehensive line of checkweighers from Wipotec is surely the right decision. The scales determine precise weight values while controlling goods and material flows and providing remarkable throughput rates facilitated by high speed operations. Simple to use and easy to integrate in your existing conveyor systems, these machine guarantee the highest precision and service life. ▲

Wipotec portfolio of heavy load checkweighers:

- EC-E-SL – the entry machine
- HC-M-SL – base model with a gross weighing range up to 60 kg
- HC-M-WD-SL – for heavy loads in wash-down applications (IP69K)
- HC-M-MDi-SL – in combination with metal detection



HC-M-WD-SL



HC-M-MDi-SL

/ Advanced x-ray technology:

Ensuring product safety and brand protection are our biggest priorities

In the industrial manufacturing of products, quality must be given the highest priority in all production processes. Against the backdrop of utmost concern for customer safety, supplying defective goods can quickly result in fatal consequences. Recall actions are extremely costly and may irreparably damage your image as a reliable producer. Even worse are the health risks passed on to the consumer because defective products were shipped.

Wipotec inspection systems – Guarantee of quality

To ensure the shelves at the retailer do not become a safety risk, manufacturers need advanced and fully automated inspection systems that reliably and continuously guarantee quality without restricting productivity.

Wipotec is among the leading suppliers of comprehensive inspection systems worldwide. Our globally recognised cutting edge technology and our comprehensive product range of ultra-modern, high performance X-ray scanners give you the confidence of knowing you are in the best possible position in terms of quality assurance. Together with you, we create the foundation for sustained customer loyalty.

X-ray scanners from Wipotec support the efficient design of quality assurance systems on the basis of standards like HACCP, BRC, or IFS. These high-tech machines detect foreign bodies made of metal, glass, stone and plastics of different densities while checking your products for completeness, correct form and fill quantities.

Wipotec Portfolio: X-ray and optical inspection systems



Functionality & Performance 

- SC** Scanning – Premium X-ray inspection for high performance applications
- E** Essential – X-ray inspection for basic applications, best price-performance ratio

/ Checkweigher and X-ray inspection in a space saving unit

The SC-W series is a pioneering combination of innovative X-ray technology and the proven checkweigher technology from Wipotec. The products in the accepted goods stream are checked not only for impurities, but also undergo a high-precision weight control check. Units with an incorrect weight are ejected into a separate container.

Both the single and the dual-track model are very successful – either with or without the curtain for radiation protection. The variant without protective curtain provides high throughput rates of up to 300 packages per minute per track, which is even possible for very lightweight product units.

The tool-free exchange of all conveyor belts and the easy to handle housing make it really simple to clean the system. The product area is separated from all of the drive system components.

All of the X-ray scanners from Wipotec have the same familiar and convenient user interface found in the checkweigher line. The system is controlled from a 15" colour TFT display with touchscreen panel that always shows the current X-ray image and product weight. Designed for protection class IP65 with full stainless steel construction, the system features a balcony design and sloped surfaces that, together with C-shaped product area, enable thorough cleaning, quickly and easily. All scanners meet the most stringent standards of hygiene.



Main Features

- X-ray scanner and checkweigher in one unit
- Flexible component design
- Available as single or dual-track system

Your Benefits

- X-ray scanner and checkweigher for maximum product safety
- Easy to operate central user interface

/ Röntgeninspektion und optische Kontrolle in einer kompakten Bauform

Das Modell SC-V gehört zu den Vertretern modernster Inspektionstechnik. Es verbindet das zuverlässige Aufspüren von Produktfremdkörpern per Hochleistungs-Röntgenscanner mit zusätzlichen im Hause Wipotec entwickelten optischen Kontrollsystemen.

Diese Kontrollsysteme überprüfen auf den Produkten aufgedruckte Informationen (Chargedaten, Nährwerte, Haltbarkeit) auf Richtigkeit und ein makelloses Erscheinungsbild im Hinblick auf die korrekte Positionierung und Lesbarkeit aller Labels und Etiketten. Beide Inspektionseinheiten, Röntgentechnik und optische Kontrolle, sind platzsparend in einer Bauform kombiniert.

Die SC-V sichert Ihnen damit neben einer zuverlässigen Fremdkörperkontrolle zusätzlich ein akkurates und gleichmäßiges Erscheinungsbild Ihrer Produkte zu. Das Modell steht für eine herausragende Inspektionstechnik, die größtmögliche Sicherheit bietet und teure Rückrufe infolge von Produktverunreinigungen oder fehlerhafter Etikettierung nachhaltig verhindert.

Das Modell übernimmt die aus der Sparte Kontrollwaagen bekannte komfortable Bedienoberfläche. Die Steuerung des Systems erfolgt über einen 19" Farb-TFT mit Touchscreen, der stets die aktuellen Inspektionsbilder anzeigt.

Die SC-V besteht komplett aus Edelstahl und erfüllt die Schutzklasse IP54. Die Balkonarchitektur ermöglicht in Verbindung mit dem in C-Form realisierten Produktraum und den abgeschrägten Flächen eine einfache, schnelle und gründliche Reinigung. Die Maschine erfüllt höchste Hygieneanforderungen. ▲

Englisch fehlt



Wichtigste Features

- Multiple Inspektionsmöglichkeiten in einer kompakten Einheit
- Lesbarkeits-Check und Positionskontrolle aller Labels und Etiketten
- Deckfolien-Verifikation
- MHD-Überprüfung
- Barcodeprüfung
- Höchste Modularität im Aufbau
- Für höchste Hygieneanforderungen
- Bedienung beider Inspektionseinheiten über nur ein HMI

Ihre Benefits

- Umfassendste Inspektion für maximale Produktsicherheit und Qualität
- Ein zentrales HMI für einfachste Bedienung

/ **Zuverlässiger Experten-Service,** zugeschnitten auf ihre Bedürfnisse

Wenn Sie sich für Wipotec als Ihren zukünftigen Systemlieferanten entscheiden, profitieren Sie von unserer langjährigen Serviceerfahrung mit Wäge- und Inspektionlösungen. Vom reinen Beratungsservice bis zum konkreten Linien- und Produktsupport über den gesamten Produktlebenszyklus sind wir Ihr zuverlässiger Partner.

Wenden Sie sich bezüglich Ihrer Anforderungen vertrauensvoll an uns. Gerne beraten wir Sie im persönlichen Gespräch detailliert über den Umfang und die Ausführung der einzelnen Serviceleistungen. Vertrauen Sie unserer Erfahrung und Zuverlässigkeit. ▲

Englisch fehlt



Herausragende Serviceleistungen, von denen Sie profitieren

- 24/7* – Ständige Erreichbarkeit per Hotline
- Weltweites Servicenetz mit autorisierten Technikern für den Einsatz vor Ort
- Professionelle Installation und Optimierung auf Kundenanforderung für einen reibungslosen Gerätestart
- Europaweite Konformitätsbewertung sowie Instandsetzung beim Tausch eichrelevanter Teile
- Vorbeugende Wartung, Aufbereitung und Optimierung Ihrer Systeme
- Schnelle Reparaturen vor Ort unter Verwendung von Originalteilen
- Überprüfung der Kalibrierung und bei Bedarf Neujustierung der Gesamtsysteme
- Allgemeine und gezielte Produktschulungen für mehr Effizienz
- Fernwartung (bei entsprechender Hardware) zur sofortigen Hilfe aus erster Hand

* Bei Abschluss eines entsprechenden Servicevertrags

Bringen Sie Ihre Produktion auf das höchste Niveau:

Schnell, kostensparend und
gewinnbringend!

Englisch fehlt

Sprechen Sie uns an!

2,5386

3,2084

2,9247

9:40

10:08

10:34

11:29

11:46

12:05

12:58

Headquarters

Wipotec GmbH
Adam-Hoffmann-Str. 26
67657 Kaiserslautern
Germany

T +49 631 34146-0
F +49 631 34146-8690
info@wipotec.com
wipotec.com

WIPOTEC 